

KAWASAKI Z900

PORTATARGA / PLATE HOLDER

PRTR011

FRONT VIEW

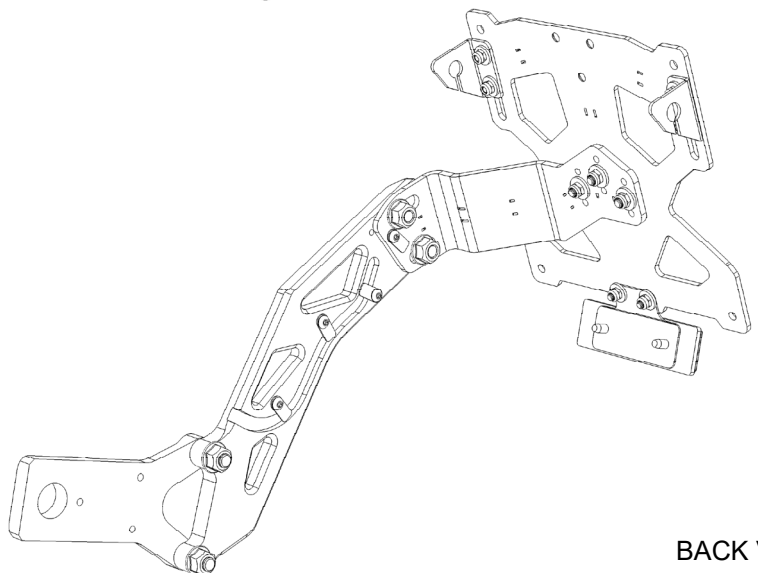
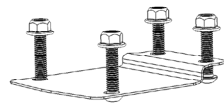
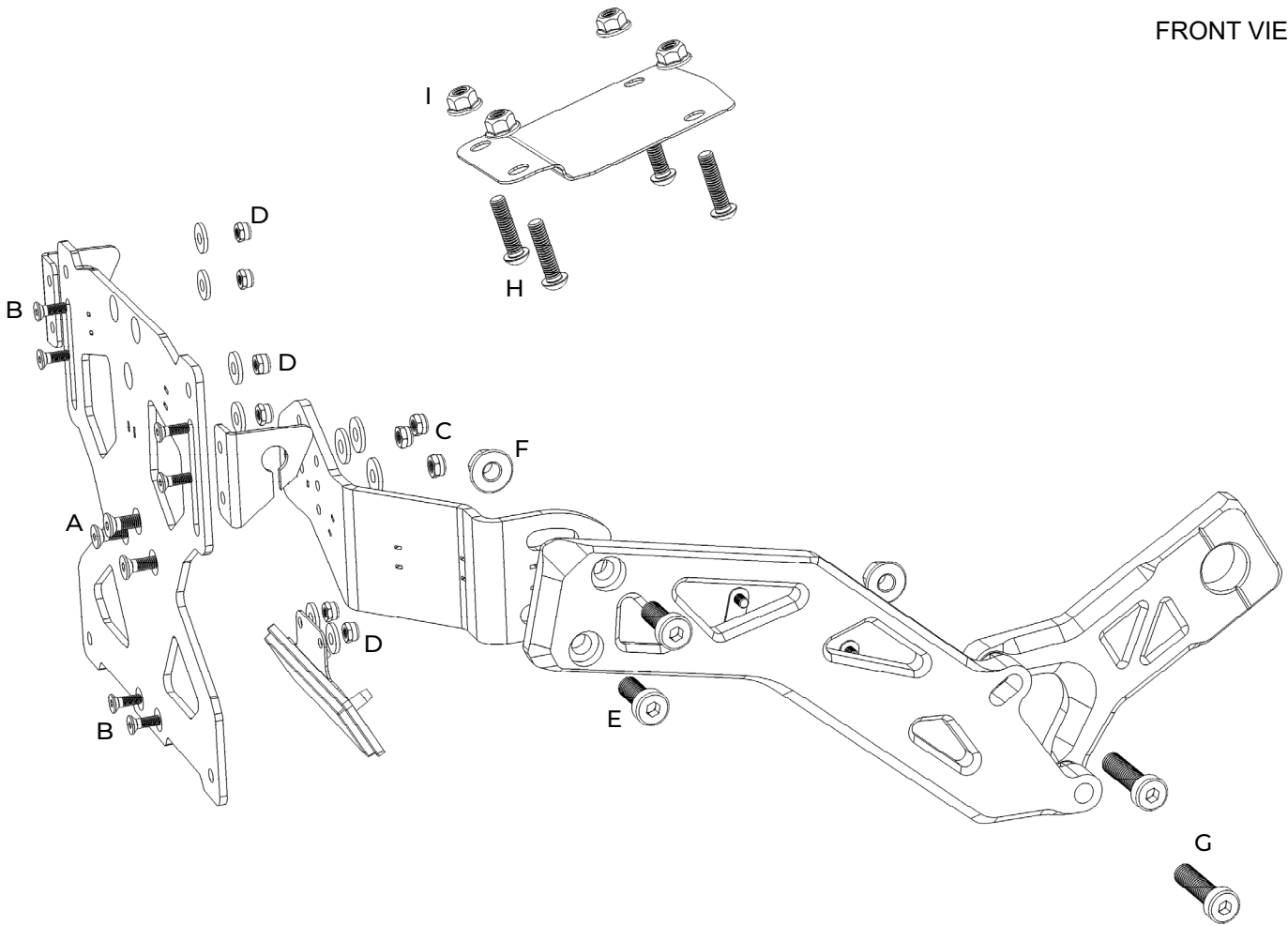

BACK VIEW

LETTER	DESCRIPTION	UNITS
A	Vite svasata M5 M5 Countersunk screw	3
B	Vite svasata M4 M4 Countersunk screw	6
C	Dadi autobloccanti M5 M5 Lock nut	3
D	Dadi autobloccanti M4 M4 Lock nut	6
E	Vite M8 L.25 M8 L. 25Screw	2
F	Dado autobloccante M8 M8 Flange head lock nut	4
G	Vite M8 L.30 M8 L.30 Screw	2
H	Vite M6 H25 M6 H25 Screw	4
I	Dado autobloccante M6 M6 Flange head lock nut	4

Cablaggio
Wiring

1. Smontare il perno ruota posteriore e sostituire al tendicatena presente il supporto portatarga king.
Remove wheel pivot and change the chain adjuster with the license plate holder.

2. Rimontare il perno ruota (prestare attenzione sia alla tensione catena sia al corretto allineamento della ruota posteriore).
Secure the wheel pivot (pay attention to the chain tension and the wheel alignment).

3. Montare la staffa del portatarga sul supporto montato in precedenza.
fix the bracket to the one mounted previously.

4. Montare il supporto della tabella portatarga sulla staffa montata al punto 3.
Fix the license plate holder to the bracket mounted at point 3.

5. Montare la tabella portatarga sul relativo supporto montato in precedenza.
Screw the license plate to its bracket built so far.

6. Disporre il cablaggio facendogli seguire il percorso del filo sensore ABS bloccandolo con le fascette.
 Far passare il cablaggio all'interno del vano sottosella portandolo in prossimità dei connettori.
Arrange the wiring following the ABS sensor cable fixing with cable bands. Take the wiring to tail section.

1.



2.



3.



4.



5.

